

DOOR AND DRAWER STYLE SELECTION

Choosing Your Door And Drawer Style

The one thing that will affect the look of your kitchen perhaps more than anything else is the style of your cabinet door and drawer fronts. And there are many styles available to you. Traditional cope and stick, slab, or mitered construction. Raised or flat (recessed) panels. Ogee, square, or regular beads. And more...So many choices!

I'd like to take a moment to help parse out the details. We'll look at the different types of construction, the options for material, edge, bead, and panel profiles, and some other door and drawer choices that may interest you.

Construction

There are three main types of door construction:

1. Traditional (also known as mortised or cope and stick)
2. Mitered
3. Slab

Traditional Doors





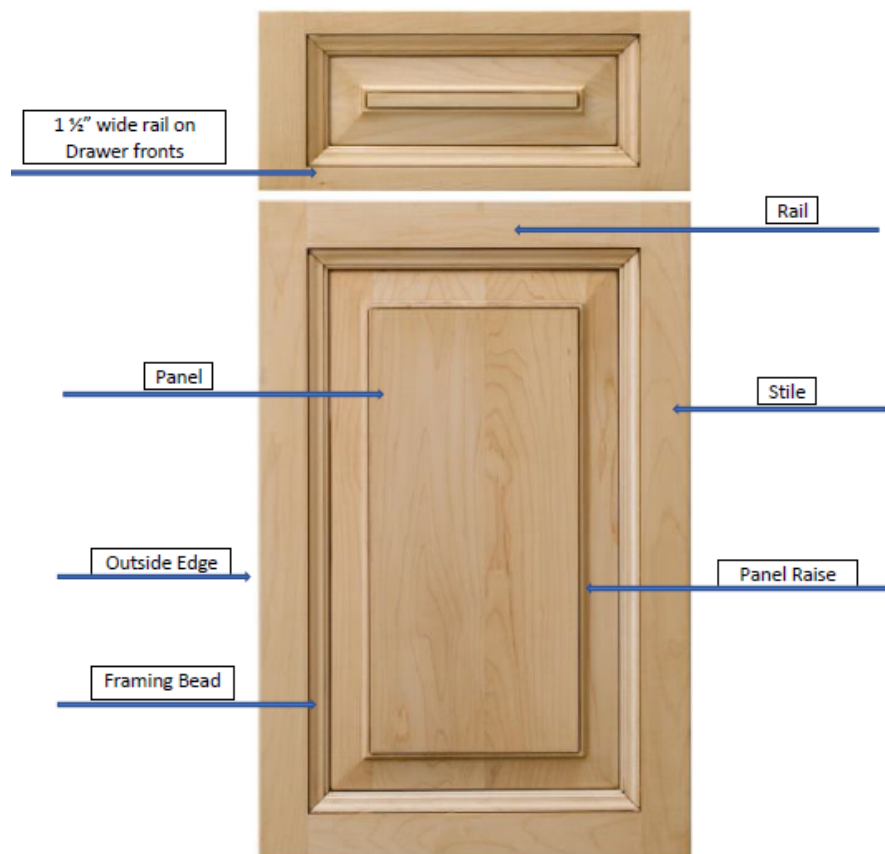

A door or drawer style called "Traditional" is made of five pieces, which is why they are sometimes called "5-Piece doors" or "5-Piece drawers".

Think of this type of door as a picture frame that has a top and bottom rail (the horizontal members of the frame), a left and right stile (the vertical members of the frame) that together house a center panel (which is where the glass would be in a picture frame).

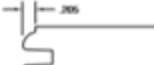
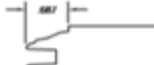

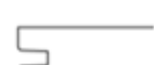
For the frame, you can choose the style of the outside edge profile and the framing bead, which is the inside edge profile.

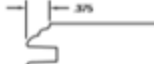
Edge Profiles				
 B 3/4" only Rabbit: 7/16" deep 3/8" high	 B-2⁺ 3/4" and 1" Available w/MDF	 C 3/4" only Rabbit: 7/16" deep 3/8" high	 C-2⁺ 3/4" and 1" Available w/MDF	 CFP-2⁺ 3/4" and 1"
 E-2⁺ 3/4" and 1"	 FP 3/4" only	 H-2⁺ 3/4" and 1" Available w/MDF	 J-2⁺ 3/4" and 1"	 L-034⁺ 3/4" and 1" Available w/MDF
 L-059⁺ 3/4" and 1" Available w/MDF	 L-120⁺ 3/4" and 1"	 L-149⁺ 3/4" and 1" Available w/MDF	 L-253 3/4" and 1" 5" back bevel Available w/MDF	 L-281⁺ 3/4" and 1"
 L-382⁺ 3/4" and 1" Available w/MDF	 L-686 3/4" and 1" 5" back bevel Available w/MDF	 L-772⁺ 3/4" and 1"	 L-803⁺ 3/4" and 1" Available w/MDF	 L-1160⁺ 3/4" and 1" Available w/MDF
 LC-2⁺ 3/4" and 1" Available w/MDF	 Machine Edge⁺ 3/4" and 1" Available w/MDF	 PRS-2⁺ 3/4" and 1" Available w/MDF	 RC-2⁺ 3/4" and 1"	 V-2⁺ 3/4" and 1" Available w/MDF

Framing Beads			
 Regular 3/4" and 1"	 Elite 3/4" only	 Ogee 3/4" and 1"	 Square 3/4" and 1"
 F-007 3/4" only	 F-877 3/4" only	 F-1223 3/4" only	

Further, you can choose either a raised or flat center panel. If you choose a raised panel, then you will have to decide on the raised panel profiles from a number of options.

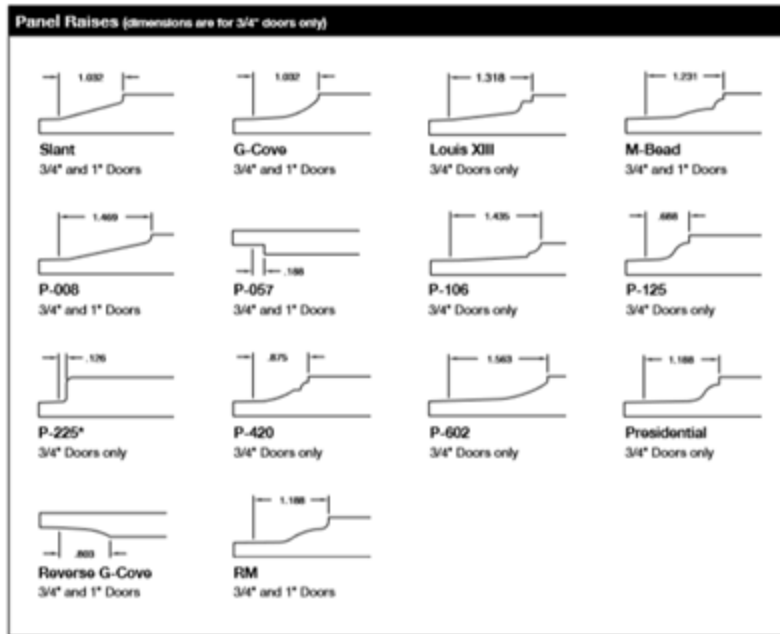

Mitered Doors

A mitered door also has five pieces, but on this door style, the corners are mitered together. Because they are mitered, you can have a door with more detail. Mitered doors can't be used on inset cabinetry.

If you choose a mitered door style and want painted cabinets, I recommend a door with a frame that is 3 1/4" or less, as the miters may open with seasonal temperature and humidity changes. This is normal but something to keep in mind.

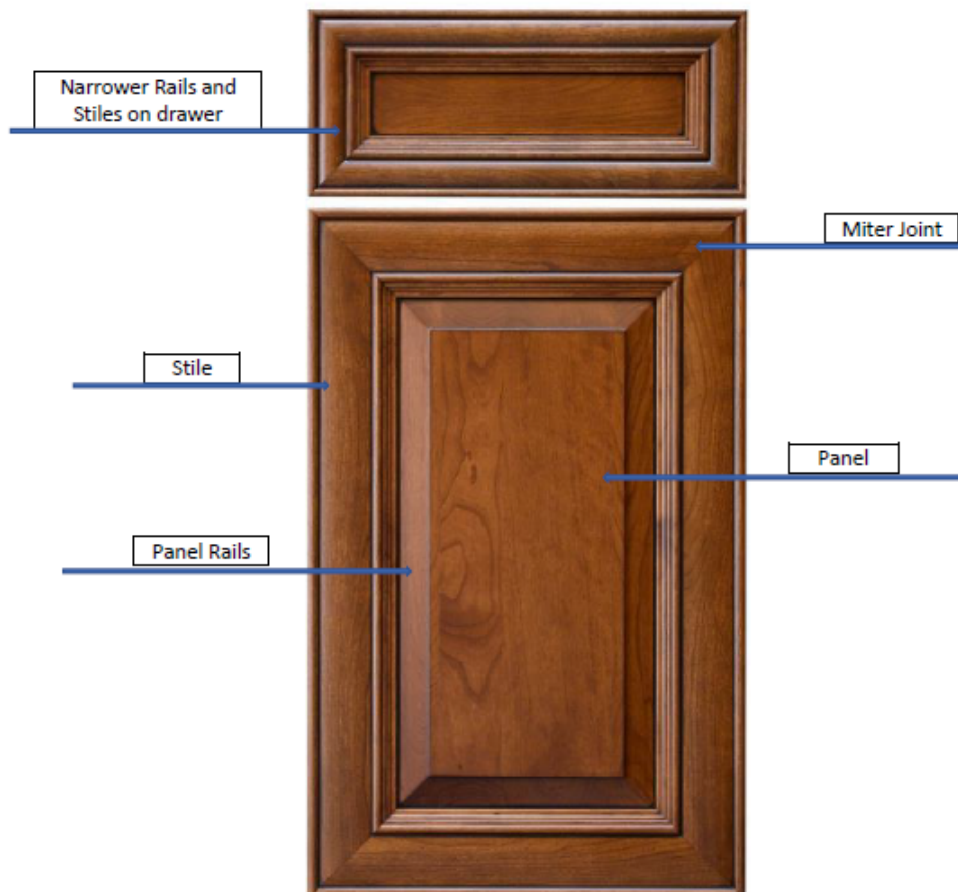

Applied Moulding Doors

Applied moulding doors have a separate piece of moulding attached to each member of the door frame. These can be simple or more ornate, like rope, egg-and-dart, or other carved mouldings. Doors with applied mouldings tend to be more elaborate, but simpler designs are available as well. They also cost a bit more than other door styles.



Slab Doors

A slab door has a flat, smooth door front. There are two basic methods to building slab doors: (1) glued-up solid wood, or (2) sheet goods.

Often slab doors will have a square outside edge, although on a solid wood door, you do have the option for a shaped outside edge.

With a glued-up solid door, the manufacturer will glue narrow pieces of wood together to form a larger door. It gives the door a warm, deep, natural look that many people like. I recommend that a batten is used when this style is chosen as it will help keep the door stable with seasonal changes. A batten is a solid strip of wood fastened on the back of the door. This will help keep the door from warping during regular seasonal temperature changes.

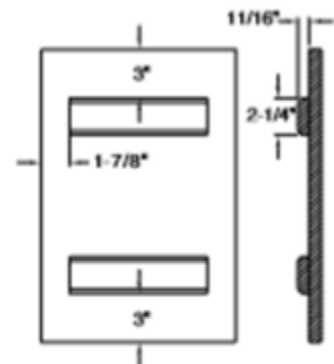

Batten Specifications

Batten location - 3" from top and bottom of door. 1-7/8" from each door edge.

Slab Doors (continued)

If you don't like battens, you may want to consider a door made from sheet goods.

A sheet goods door is a plywood or MDF door that has a veneer face and back and edge-banded sides. The advantage to this method of building a door is there is no need for a batten as plywood and MDF are very stable. Though, in my opinion, there is not as much "life" or depth to the veneer as there is in solid wood doors.

Something visually interesting that can be done with veneered doors is called a sequential match. This means that the same piece of veneer is used on abutting doors and drawers. This is usually done on more contemporary cabinets.

Slab Door and Drawer with Square Outside Edge



Slab Door and Drawer with Vertical Stiles



Aluminum Doors

Aluminum doors are gaining popularity as accent pieces in kitchens and other spaces. They add an element of interest and draw your eye to a cool, modern touch. They can be fitted with clear glass, or any number of specialty glass types, such as frosted, reeded, or water glass, among others.



Drawers

A standard drawer will have a 2 ¼" frame, but there are many options for drawers with frames as wide as 4", and wider!

Something to keep in mind is that shallower drawers, such as top drawers, will have a 1 ½" top and bottom rail. The stiles will match the stile width of the doors.

Mitered drawers will also have a smaller frame, usually 1 ½" on both rails and stiles. Also on the same drawers, you should be careful about using a raised panel as you can quickly run out of space for your drawer pulls. Perhaps consider using a flat panel instead.

While we are talking about flat panels, high end, custom cabinet manufacturers, like Brighton or Hickory Creek, will use a 3/8" center panel. This accomplishes two things:

1. It gives doors a more solid feel. Manufacturers that use lower quality materials in their cabinets use ¼" thick flat panels, which feel light and flimsy.
2. When the drawer hardware is installed on a ¼" flat panel, the screws will "suck" the panel into the drawer box and the panel will bow. This will not happen with a 3/8" thick panel.

Some people may prefer the look of a flat, smooth, slab drawer front. Others feel slab drawer fronts are too "plain looking" when compared to a 5-piece drawer. I feel that once you install a nice drawer pull, it no longer looks "boring".

If you choose a slab drawer front, I definitely recommend using 5-piece drawers for the bottom drawers in your drawer base cabinets when your doors are 5-piece doors.

If you are using a raised panel door, another drawer front option is a 1 ¼" thick slab drawer in which the same detail that you use on the door panel raise is used as the outside edge of the drawer front.



1 1/4" Thick Slab Drawer With Outside Edge that Matches Door Panel Raise

Materials

Today about 70% of cabinetry is painted. Often painted doors are made from Maple with an MDF center panel. Some people recoil when I mention the MDF panel, but rest assured this is a great material for center panels as it does not warp, swell, or separate the way solid wood, or even plywood, can. You can even go one step further and have a door made completely from MDF, which is great because the joints where the stile and rail meet will not have any “cracks” in the paint as can happen with solid wood.

If you like the look of stained cabinetry, you can have your choice of many wood species, such as Cherry, Maple, Oak, Rift or Quarter Sawn Oak, Walnut, and Alder. Renewable products such as Lyptus and Bamboo are available, as well as exotics like Zebra or Cocobolo, and on, and on, and on.

Most Popular Doors

In this age of Transitional Design, doors with simple lines and flat panels are king. I would like to finish this article by showing you the doors my customers choose most often. Notice that they are simple in design with straight, pleasing-to-the-eye lines to complement today’s popular Transitional style. These doors fit in well with a kitchen that is dressed up or simple and understated. Enjoy!



Cascade Door Style with 5-Piece
Drawer



Amesbury Door With Slab Drawer



Shaker Door Style With Slab Drawer
(3" rails and stiles)

Most Popular Doors (continued)



Verona Door Style with 5-Piece Drawer
(Applied Moulding)



Thompson Door with Slab Drawer